

MANDRINO PER PUNTE DA CENTRI

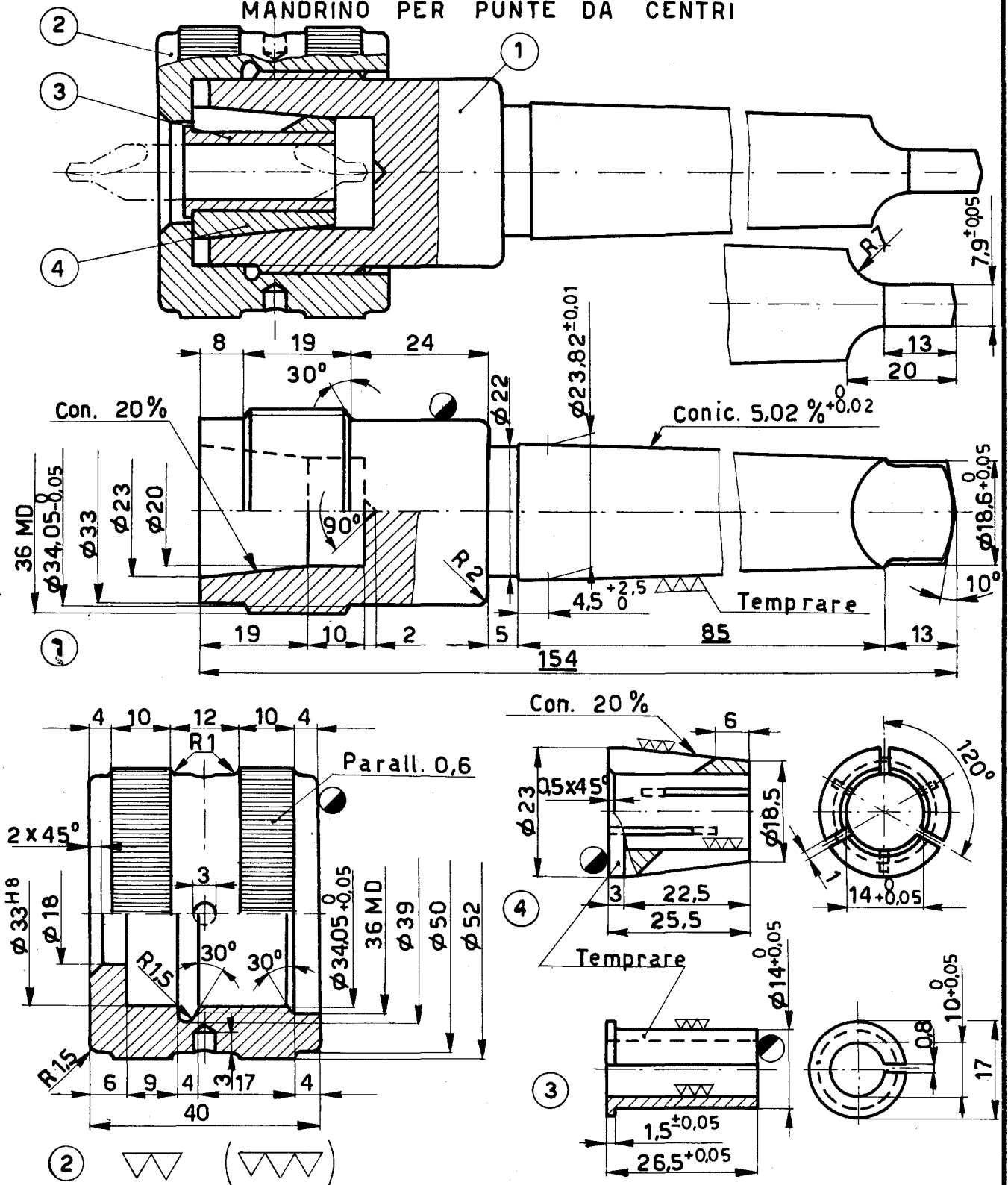

4	BUSSOLA SCOMPONIBILE	1	∅ 25 x 30	12 NC 3	Temp.
3	BUSSOLA ELASTICA	1	∅ 18 x 30	12 NC 3	Temp.
2	MANICOTO FILETTATO	1	∅ 55 x 45	12 NC 3	Bonif.
1	CODULO DI ATTACCO	1	∅ 55 x 160	12 NC 3	Cem. e temp.
POS.	DENOMINAZIONE	QUANT.	DIMENS. GREZZO	MATERIALE	NOTE

TOLLERANZE
± 0,1

TEMPO CONCESSO 40 ore

SCALA 1:1



ESERCIZIO PROPOSTO DA

I. P. S. GORIZIA